

TMC2070P7C

Parallel to RBUS adapter

Features

- Parallel Input
- RBUS Output
- Raytheon demo board compatibility

Applications

- Evaluation of Raytheon demo boards
- System Breadboarding

Description

The TMC2070P7C RBUS adapter provides a simple interface between a computer parallel port and RBUS. It can be used with standard I2C drivers or the Raytheon Raydemo software.

This adapter requires a bi-directional parallel port. Power is supplied through the connectors. Be careful when using a parallel cable with this product. Some cables flip pins between the input and output connectors which may cause undesirable results.

Block Diagram

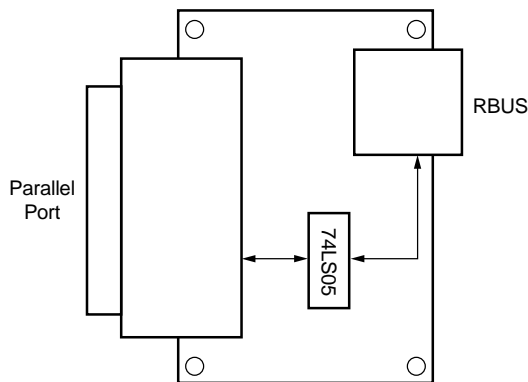

Preliminary Information

Table 1. TMC2070P7C Parts List

Item	Qty.	Part Name	Reference Designator	Description
1	1	MiniReel: 444-810	C1	10uf 16v
2	1	SN74LS05DN	U1	IC, 74LS05 surface mount
3	1	RS6A103G	RN1	10k ohm 6 pin Sip res.
4	1	AMP: 747842-4	P1	25 pin D Sub connector
5	1	Molex: 444-810	P2	ACCESS bus Plug

Preliminary Information

Schematic

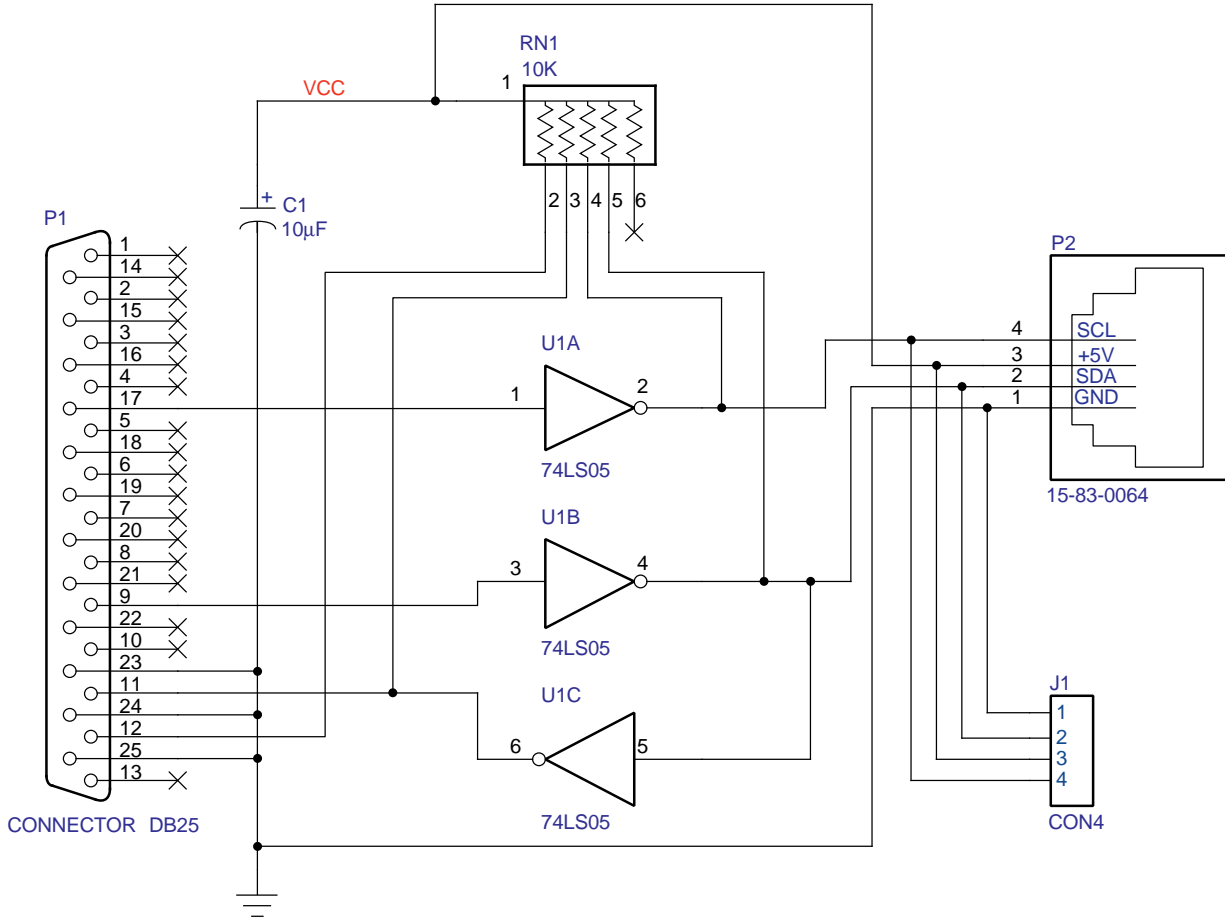

Figure 1. TMC2070P7C

Preliminary Information

Related Products

- TMC2068P7C Decoder demonstration board
- Raydemo software

Ordering Information

Product Number	Temperature Range	Speed Grade	Screening	Package	Package Marking
TMC2070P7C	25°C	100 KHz	Commercial	1" by 2" Printed Circuit Board	TMC2070P7C

A schematic database is available in OrCAD™ format. Contact the factory.

The TMC2070P7C Demonstration Board, design documentation, and software are provided as a design example for the customers of Raytheon. Raytheon makes no warranties, express, statutory, or implied regarding merchantability or fitness for a particular purpose.

All parameters contained in this specification are guaranteed by design, characterization, sample testing or 100% testing as appropriate. Raytheon reserves the right to change products and specifications without notice. This information does not convey any license under patent rights of Raytheon Company or others.

FCC Compliance

This device has not been approved by the Federal Communications Commission (FCC). This board is intended for the evaluation of Raytheon products only. This device is not and may not be offered for sale or lease or sold or leased until the approval of the FCC has been obtained.

Preliminary Information

The information contained in this data sheet has been carefully compiled; however, it shall not by implication or otherwise become part of the terms and conditions of any subsequent sale. Raytheon's liability shall be determined solely by its standard terms and conditions of sale. No representation as to application or use or that the circuits are either licensed or free from patent infringement is intended or implied. Raytheon reserves the right to change the circuitry and any other data at any time without notice and assumes no liability for errors.

LIFE SUPPORT POLICY:

Raytheon's products are not designed for use in life support applications, wherein a failure or malfunction of the component can reasonably be expected to result in personal injury. The user of Raytheon components in life support applications assumes all risk of such use and indemnifies Raytheon Company against all damages.

Raytheon Electronics
Semiconductor Division
5580 Morehouse Drive
San Diego, CA 92121
619.457.1000
800.722.7074
Fax 619.455.6314
applications@lj.sd.ray.com